

DYTRAN PROPRIETARY AND CONFIDENTIAL
 THE INFORMATION CONTAINED IN THIS DRAWING IS THE SOLE PROPERTY OF
 DYTRAN INSTRUMENTS, INC. AND ANY REPRODUCTION IN PART OR AS A WHOLE
 OR ANY OTHER DISSEMINATION OF THIS INFORMATION WITHOUT THE WRITTEN
 PERMISSION OF DYTRAN INSTRUMENTS, INC. IS PROHIBITED.

MODEL	SENSITIVITY
3032A	10 mV/G
3032A2	2 mV/G

REV	ECN	DESCRIPTION	BY/DATE	CHK	APPR
B	7725	UPDATED MARKING, CABLE VIEW	RLA 08/03/11	DV	ANS
C	9989	UPDATED VIEW OF CONNECTOR	AB 06/03/13	JS	DV
D	13148	ADDED: MODEL 3032A2 AND MODEL TABLE	LA 12/01/16	MH	AE

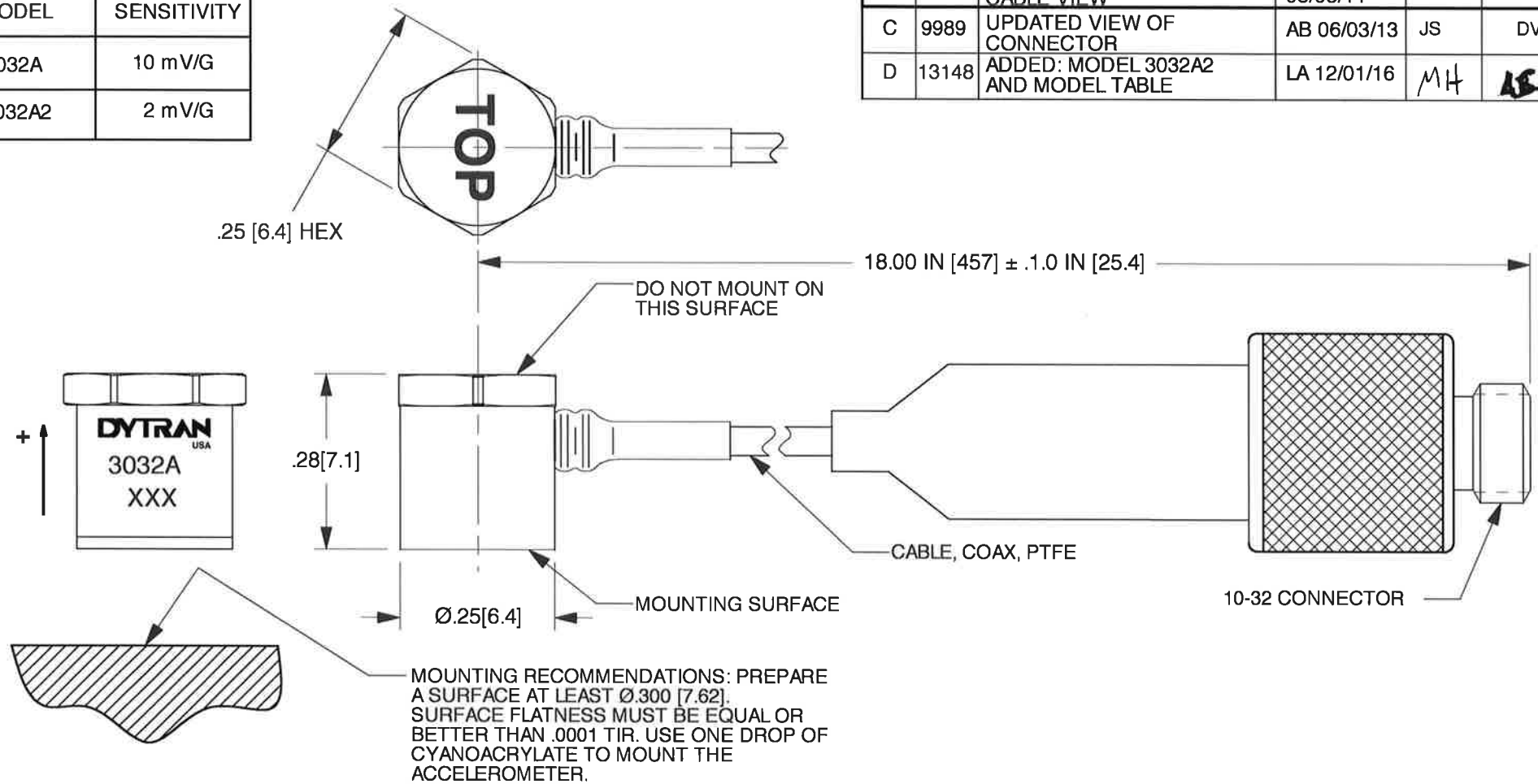

- 3. HOUSING MATERIAL: TITANIUM
- 2. WEIGHT (LESS CABLE): 1.5 GRAMS
- 1. TO REMOVE, (UN-INSTALL) TORQUE GENTLY ON HEX UNTIL ADHESIVE JOINT FAILS IN SHEAR. DO NOT STRIKE TO REMOVE.

NOTES: UNLESS OTHERWISE SPECIFIED

UNLESS OTHERWISE SPECIFIED: INTERPRET DIM & TOL PER ASME Y14.5M-1994 REMOVE BURRS COUNTERSINKS INTERNAL THDS 90° TO MAJOR DIA CHAM EXT THDS 45° TO MAJOR DIA THD LENGTHS AND DEPTHS ARE FOR THDS PER MIL-S- 7742. DIMENSIONS APPLY AFTER FINISHING.	CONTRACT NO
UNLESS OTHERWISE SPECIFIED DIMENSIONS ARE IN INCHES. DIMENSION IN BRACKETS [] ARE IN MILLIMETERS. TOLERANCES ARE: INCHES METRIC ANGLES .XX ± .03 .X ± 0.8 ± 1° .XXX ± 0.10 .XX ± 0.25	FINISH
ALL MACHINED SURFACES TOTAL RUNOUT WITHIN .005 BREAK SHARP EDGES .005 TO .010 MACHINE FILLET RADI .005 TO .015. WELDING SYMBOLS PER AWS A2.4 ABBREVIATIONS PER MIL-STD-12	DO NOT SCALE DRAWING

DYTRAN **MASTER**
INSTRUMENTS, INC. **ONLY IF IN RED** CHATSWORTH, CA.

SCALE 4X	DESIGN NC	DATE 10/23/98			
DRAWN NC	DATE 10/23/98	PART NO.			
CHECKED R.A.	DATE 10/23/98	MAT'L			REV D
APPROVED N.C.	DATE 10/23/98	NEXT ASSEMBLY		USED ON	
TITLE OUTLINE/INSTALLATION DRAWING, MODEL 3032A			DWG NO. 127-3032A		
			SHEET 1 OF 1		



- MINIATURE SIZE
- FULL LASER WELDED BODY
- EPOXY SEALED CABLE CONNECTION

PHYSICAL

Weight, including cable		0.2	oz	6	grams
Size, accelerometer	Hex x Height	.25 x .28	Inches	6.35 x 7.11	mm
Mounting Provision [4]		Adhesive Mount		Adhesive Mount	
Connector		10-32, UNF-2A		10-32, UNF-2A	
Housing	Material	Ti 6Al-4V		Ti 6Al-4V	
Sensing	Material	Quartz		Quartz	
	Mode	Shear		Shear	

PERFORMANCE

Sensitivity, ±10% [1]	10	mV/g	1.0	mV/m/s ²
Range F.S for ± 5 Volts Output	±500	g	±4905	m/s ²
Frequency Response, ± 10%	1 to 10000	Hz	1 to 10000	Hz
Frequency Response, ± 3dB	.45 to 12000	Hz	.45 to 12000	Hz
Resonant Frequency, Nominal	> 80	kHz	> 80	kHz
Equivalent Electrical Noise (Resolution) [5]	0.007	grms	0.07	m/s ² rms
Linearity [2]	± 2	% F.S.	± 2	% F.S.
Maximum Transverse Sensitivity	5	%	5	%
Strain Sensitivity @ 250 µε	0.001	g/µε	0.01	m/s ² /µε

ENVIRONMENTAL

Maximum Vibration	±1000	g's, peak	±9810	m/s ² peak
Maximum Shock	±1500	g's, peak	±14715	m/s ² peak
Temperature Range (Accelerometer)	-60 to 250	°F	-51 to 121	°C
Seal	Epoxy/Weld		Epoxy/Weld	

Electrical

Supply Current Range [3]	2 to 20	mA	2 to 20	mA
Compliance Voltage Range	+20 to +30	Volts	+20 to +30	Volts
Output Impedance, Typ.	100	Ω	100	Ω
Output Bias Voltage	+7 to +9	VDC	+7 to +9	VDC
Discharge Time Constant, Nom	0.4 to 1.2	Sec	0.4 to 1.2	Sec
Output Signal Polarity	Positive		Positive	

This family also includes:

Model	Sensitivity (mV/g)	Range (g's)	Time Constant (sec)	Noise, Resolution (grms)	Integral Cable Length (in)

Please, refer to the performance specifications of the products in this family for detailed description

Supplied Accessories:

- 1) Accredited calibration certificate (ISO 17025)

Notes:

- [1] Measure at 100Hz, 1 Grms per ISA RP 37.2
- [2] Measure using zero-based straight line method, % of F.S. or any lesser range.
- [3] Do not apply power to this system without current limiting, 20 mA MAX. To do so will destroy the IC charge amplifier.
- [4] Flat mounting surface for adhesive mount.
- [5] Typical. Not to exceed .010 Grms [.10 m/s²].

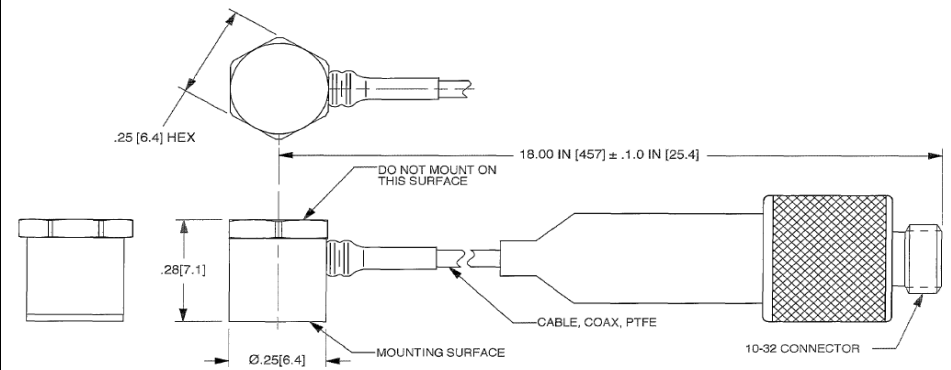
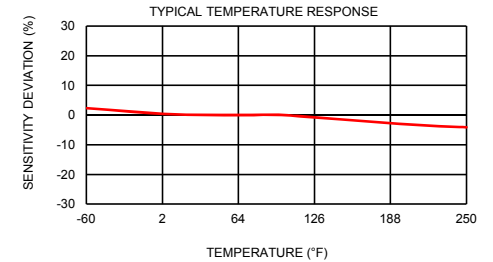
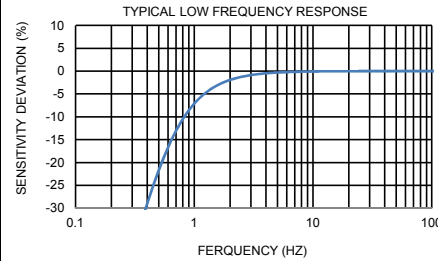

Units on the line drawing are in inches, units in brackets are in millimeters. Refer to 127-3032A for more information.

